

61850720	DATA SHEET	
Valid from: 13.04.2026	CABLE TIE DETECT	

Der Kabelbinder CABLE TIE DETECT aus Detektierbaren Polyamid, ist aufgrund seiner hohen Zugfestigkeit für den Einsatz im Lebensmittelbereich geeignet.

Material: Polyamide 6.6 – Detectable

Technical features:

Bundle diameter max. 102 mm
 Band width 2,5 up to 7,6 mm
 Tensile strength 80 up to 530 N

Additional features:

Fire classification V2 acc. to UL 94

Temperature range:

-40°C up to +120°C

Colour:

Blue

Norm Reference:



EN 62275

(Cable ties marked with an * have been tested in accordance with EN 62275)

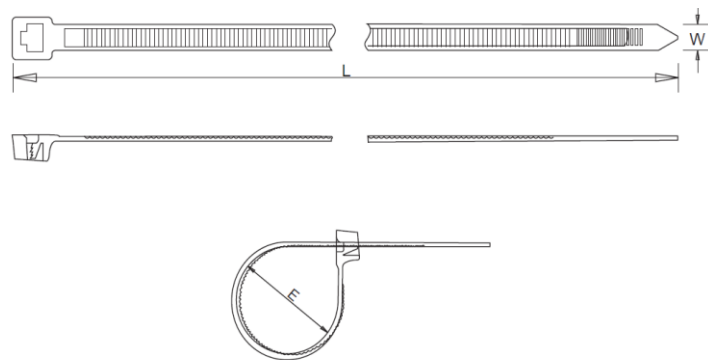

Creator: PDP Released: PDP	Document: DB61850720EN Version: 00	Page 1 of 2
-------------------------------	---------------------------------------	-------------

61850720	DATA SHEET	
Valid from: 13.04.2026	CABLE TIE DETECT	

Dimension table:

Part No.	Bundle diameter E mm	Dimensions mm		Tensile strength N
		Length l	Width w	
Blue				
61850720	21	100	2,5	80
61850725	35	150	3,6	180
61850730	50	200	4,8	222
61850735	83	300	4,8	222
61850740	102	370	4,8	222
61850745	96	370	7,6	530

* Testing of the maximum loop tensile strength

Please refer to our current catalogue for further details.

Our laboratory will be happy to advise you on resistance to aggressive media or specific oils.

Creator: PDP Released: PDP	Document: DB61850720EN Version: 00	Page 2 of 2
-------------------------------	---------------------------------------	-------------