

44424012	Montageanleitung Assembly instruction	
Gültig ab / valid from 19.01.2023	EPIC® MCS HC2 44424012 EPIC® MCB HC2 44424013	

- 1 Adern abisolieren
Strip the wires

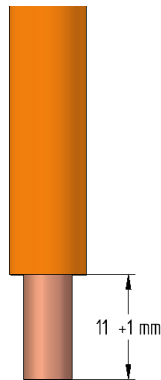

- 2 Kontakte crimpen
Crimp the contacts



- 3 Kontakte ins Modul einführen, bis ein Klick zu hören ist
Insert contacts into the modul until a click is heard

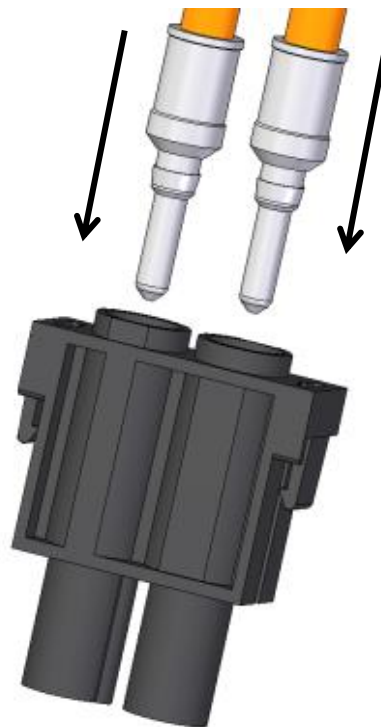

Crimpzange 11147000 und

Backen

44424016

11147111

11147210

44424012	Montageanleitung Assembly instruction	
Gültig ab / valid from 19.01.2023	EPIC® MCS HC2 44424012 EPIC® MCB HC2 44424013	

- 4 Module müssen in Rahmen einrasten
The modules must snap into the frame

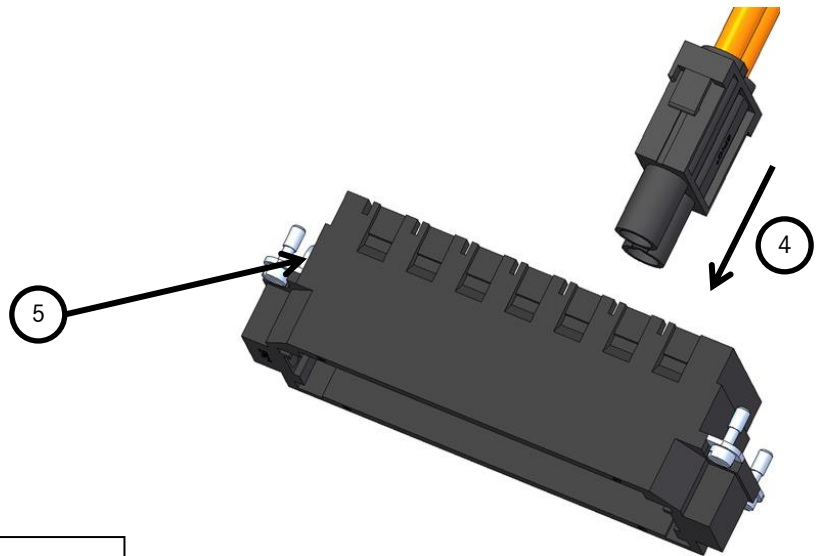

- 5 PE-Schrauben zurückdrehen
PE-Screw back the screws

- 6 Codierung ist zu beachten
Coding must be considered

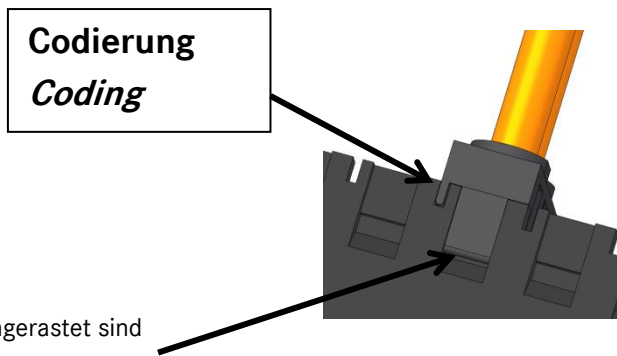

- 7 Nachprüfen, ob die Module fest eingerastet sind
Verify that the modules are fixed

- 8 Ringöse muss an den PE gecrimpt werden
Eyelet must be crimped to the PE-wire

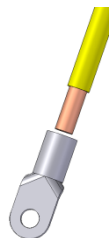

- 9 PE Schraube mit 1,2 Nm anziehen
Torque PE screw with 1,2 Nm

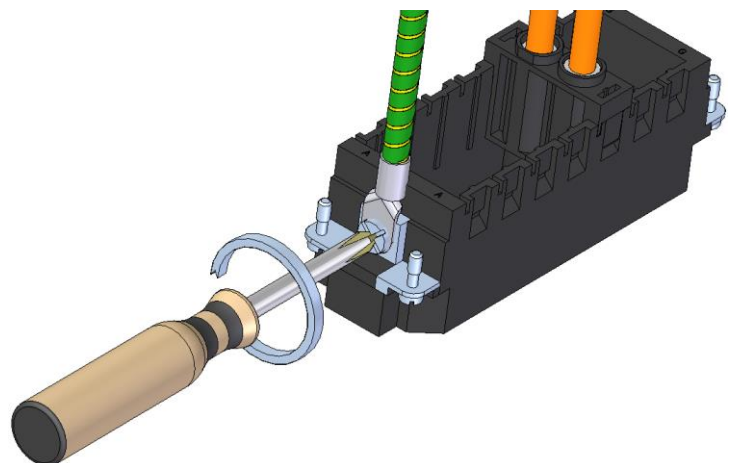

Die Seite des PE-Anschlusses kann bei Bedarf getauscht werden. Dabei ist unbedingt darauf zu achten, dass die Position des PE-Anschlusses bei Stift- und Buchse gleich sind.
The side of the PE connection can be replaced if necessary. It is essential to ensure that the position of the PE connection is the same for the pin and socket.

44424012	Montageanleitung Assembly instruction	
Gültig ab / valid from 19.01.2023	EPIC® MCS HC2 44424012 EPIC® MCB HC2 44424013	

11 Demontage der eingerasteten Kontakte mittels Lösewerkzeug. Art.-Nr.: 11171100
Removal of the snapped in contacts by using the removal tool. Art.-No.: 11171100

1. Lösewerkzeug von vorne über die Kontakte schieben.
Push des removal tool from the front side over the contacts

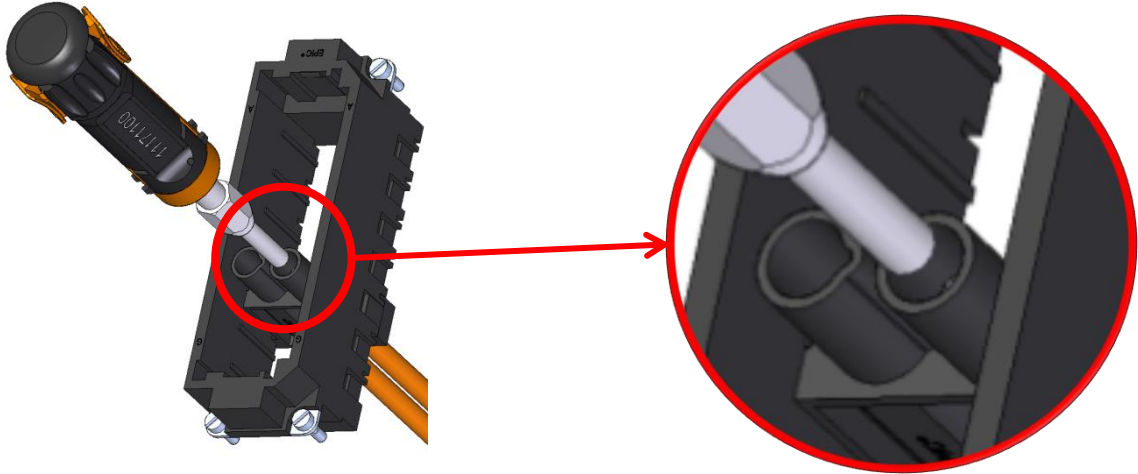

2. Das Lösewerkzeug bis zum Anschlag über den Kontaktstift schieben (Die Haltefeder wird zusammengepresst)
Pull the extraction tool over the contact pin till the end position is found. (The spring will be compressed)
3. Den Kontakt nach hinten aus der Kontaktkammer ziehen.
Remove the contact to the back side of the contact chamber.

2.

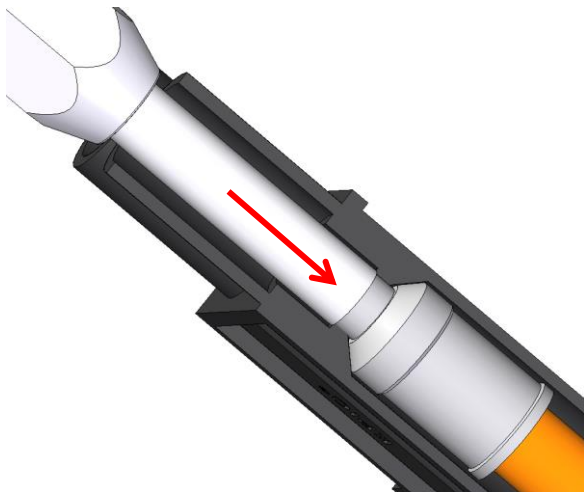

3.

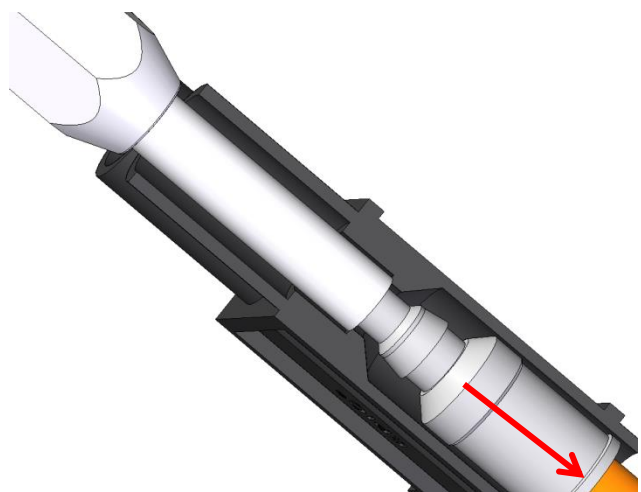

Kontakthaltefeder nach dem Lösen auf Funktion prüfen.
Check function of the locking spring after removal

44424012	Montageanleitung Assembly instruction	
Gültig ab / valid from 19.01.2023	EPIC® MCS HC2 44424012 EPIC® MCB HC2 44424013	

Kontakte :
Contacts :

EPC® Modular 3,6 gedrehte Kontakte 16 mm²					
Artikelnummer Material number	Artikelbeschreibung Material description	Kontakttyp Contact type	Leiterquerschnitt Conductor cross section	Oberfläche Surface	Abisolierlänge Stripping length
44424014	EPIC® Modular SCEM AG 16 D=3,6	Stift	16	Ag	11+1
44424015	EPIC® Modular BCEM AG 16 D=3,6	Buchse	16	Ag	11+1
44424029	EPIC® KB 16-4R	Ringöse für Schutzleiter	16		10

EPIC® MCS HC2
Polzahl: 2
Number of contacts: 2

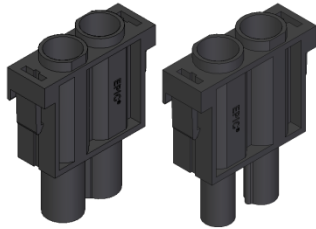

EPIC® MCB HC2
Polzahl: 2
Number of contacts: 2

Stift
Male



Buchse
Female

Rahmen:
Frame:

Buchsenrahmen:
Female Frame:





Stiftrahmen:
Male Frame:



Artikelnummer Material number	Artikelbeschreibung Material description	Kontakttyp Contact type	Slot Slot
EPIC® MCR 6 Multirahmen / Multiframe			
10381000	EPIC® MCR 6 S	Stift / male	2
10381100	EPIC® MCR 6 B	Buchse / female	2
EPIC® MCR 10 Multirahmen / Multiframe			
10381200	EPIC® MCR 10 S	Stift / male	3
10381300	EPIC® MCR 10 B	Buchse / female	3
EPIC® MCR 16 Multirahmen / Multiframe			
10381400	EPIC® MCR 16 S	Stift / male	4
10381500	EPIC® MCR 16 B	Buchse / female	4
EPIC® MCR 24 Multirahmen / Multiframe			
10381600	EPIC® MCR 24 S	Stift / male	6
10381700	EPIC® MCR 24 B	Buchse / female	6
EPIC® MC 3,6 mm Kontaktlösewerkzeug / extraction tool			
11171100	EPIC® MC Kontaktlösetool D=3,6		

44424012	Montageanleitung Assembly instruction	
Gültig ab / valid from 19.01.2023	EPIC® MCS HC2 44424012 EPIC® MCB HC2 44424013	

Werkzeuge: Zum Crimpen und Lösen der Kontakte
Tools: For crimping and loosening the contacts.

11147000	11147111	11147210	11171100
Crimpzange	Crimpbacken	Locator	Lösewerkzeug
<i>Crimping tool</i>	<i>Crimpdie</i>	<i>Crimpdie</i>	<i>Extraction tool</i>
			



ACHTUNG: NICHT UNTER LAST STECKEN ODER TRENNEN
CAUTION: DO NOT DISCONNECT UNDER LOAD



U.I. Lapp GmbH
Schulze-Delitzsch-Strasse 25
D-70565 Stuttgart
www.lappgroup.com