

ETHERLINE ACCESS BASIC LEVEL SWITCH Quick Start Guide

**ETHERLINE ACCESS U05T-E-T / U08T-E-T /
U05GT-E-T / U08GT-E-T**

Vs.01, April 2026

For more information please visit:

<https://www.lapp.com>



ETHERLINE ACCESS U05T-E-T / U08T-E-T / U05GT-E-T / U08GT-E-T

Quick Start Guide

Disclaimer: U.I. Lapp GmbH tries to keep the content of this manual as accurate and as updated as possible. This document is not guaranteed to be error-free, and we reserve the right to amend it without notice to users.

Copyright © U.I. Lapp GmbH 2026. All rights reserved.

No part of this documentation may be excerpted, reproduced, translated, annotated or duplicated, in any form or by any means without the prior written permission of U.I. Lapp GmbH.

Notice for Safety Operation

The product performs reliably as long as it is used according to the guidance. Artificial damage or destruction of the device should be avoided. Before using the device, read this notice carefully for personal and equipment safety. Please keep the manual for further reference. If the device is used not according to the specified way by LAPP, the protection provided by the device may be diminished. LAPP is not liable to any personal or equipment damage caused by violation of this notice.

- Do not place the device near water sources or damp areas. Keep the ambient relative humidity within the range from 5% to 95% (non-condensing).
- Do not place the device in an environment with high magnetic field, strong shock, or high temperature. Keep the working and storage temperatures within the allowed range.
- Install and place the device securely and firmly.
- Please keep the device clean; if necessary, wipe it with a soft cotton cloth.
- Do not place any irrelevant materials on the device or cables. Ensure adequate heat dissipation and tidy cable layout without knots.
- Wear antistatic gloves or take other protective measures when operating the device.
- Avoid any exposed metal wires because they may be oxidized or electrified.
- Install the device in accordance with related national and local regulations.
- Before power-on, make sure the power supply is within the allowed range of the device. High voltage may damage the device.
- Power connectors and other connectors should be firmly interconnected.
- Do not plug in or out the power supply with wet hands. When the device is powered on, do not touch the device or any parts with wet hands.
- Before operating a device connected to a power cable, remove all jewelry (such as rings, bracelets, watches, and necklaces) or any other metal objects, because they may cause electric shock or burns.
- Do not operate the device or connect or disconnect cables during an electrical storm.

- Use compatible connectors and cables. If you are not sure, contact our sales or technical support personnel for confirmation.
- Do not disassemble the device by yourself. When an anomaly occurs, contact our sales or technical support personnel.
- If any part is lost, contact our sales or technical support personnel to purchase the substitute. Do not purchase parts from other channels.
- Dispose of the device in accordance with relevant national provisions, preventing environmental pollution.

In the following cases, please immediately shut down your power supply and contact your LAPP representative:

- Water gets into the equipment.
- Equipment damage or shell damage.
- Equipment operation or performance has abnormally changed.
- The equipment emits odor, smoke or abnormal noise.

Contents

1 Product Overview.....	1
2 Structure and Interface	2
2.1 Front Panel.....	2
2.2 Top Panel	2
3 Mounting.....	3
3.1 Dimension Drawing.....	3
3.2 Mounting	4
3.2.1 DIN-Rail Mounting	4
3.2.2 DIN-Rail Dismounting.....	5
4 Connection	5
4.1 10/100Base-T(X)/1000 Base-T Ethernet Port.....	5
4.2 Grounding.....	6
4.3 Power Terminal Block	7
5 LEDs.....	9
6 Basic Features and Specifications	10

1 Product Overview

The ETHERLINE ACCESS U05T-E-T/U05GT-E-T/U08T-E-T/U08GT-E-T entry-level unmanaged industrial Ethernet switches, equipped with five/eight 10/100Base-T(X) Ethernet ports, are specialized designed for industrial applications.

The ETHERLINE ACCESS U05T-E-T /U08T-E-T support an extended operating temperature range of -40°C to 75 °C, 24VDC (12-52VDC) redundant power inputs, and U05GT-E-T/ U08GT-E-T an extended operating temperature range of -40°C to 75 °C, 24VDC (12-36VDC) redundant power inputs. IP40 rated metal housing, DIN-rail mounting. Their rugged, easy-to-use design makes them ideal for use in any harsh industrial environment.



Note:

This equipment has been tested and found to comply with the limits for a Class A digital device, pursuant to part 15 of the FCC Rules. These limits are designed to provide reasonable protection against harmful interference when the equipment is operated in a commercial environment. This equipment generates, uses, and can radiate radio frequency energy and, if not installed and used in accordance with the instruction manual, may cause harmful interference to radio communications. Operation of this equipment in a residential area is likely to cause harmful interference in which case the user will be required to correct the interference at his own expense.

2 Structure and Interface

2.1 Front Panel

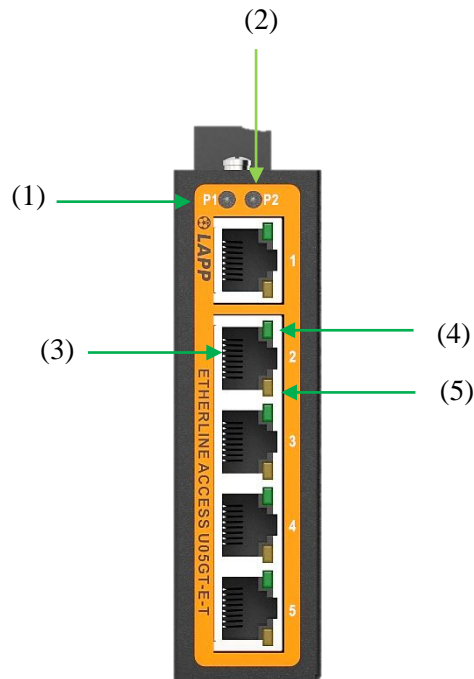

Figure 1 Front Panel

- (1) Power 1 LED
- (2) Power 2 LED
- (3) 10/100Base-T(X) Ethernet port
- (4) 10/100Base-T(X) Ethernet port connection status LED (green)
- (5) 10/100Base-T(X) Ethernet port speed LED (yellow)

2.2 Top Panel

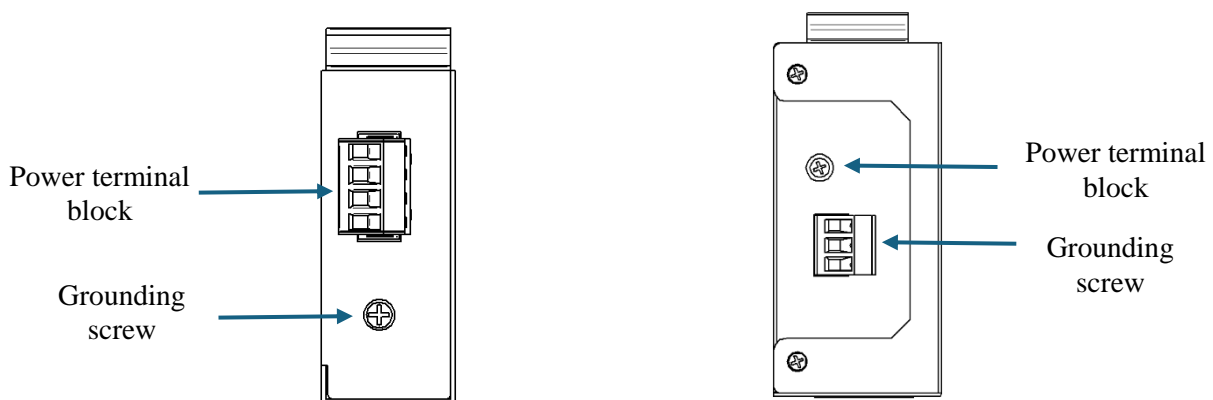

Figure 2 Top Panel

3 Mounting

3.1 Dimension Drawing

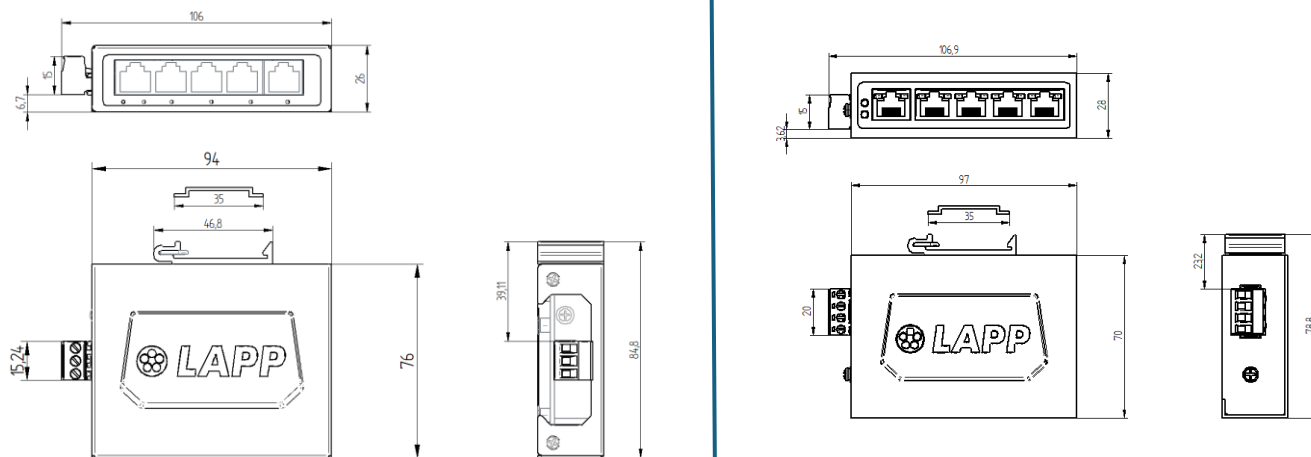

Figure 3 ETHERLINE ACCESS U05T-E-T and U05GT-E-T, Dimensions (unit: mm)

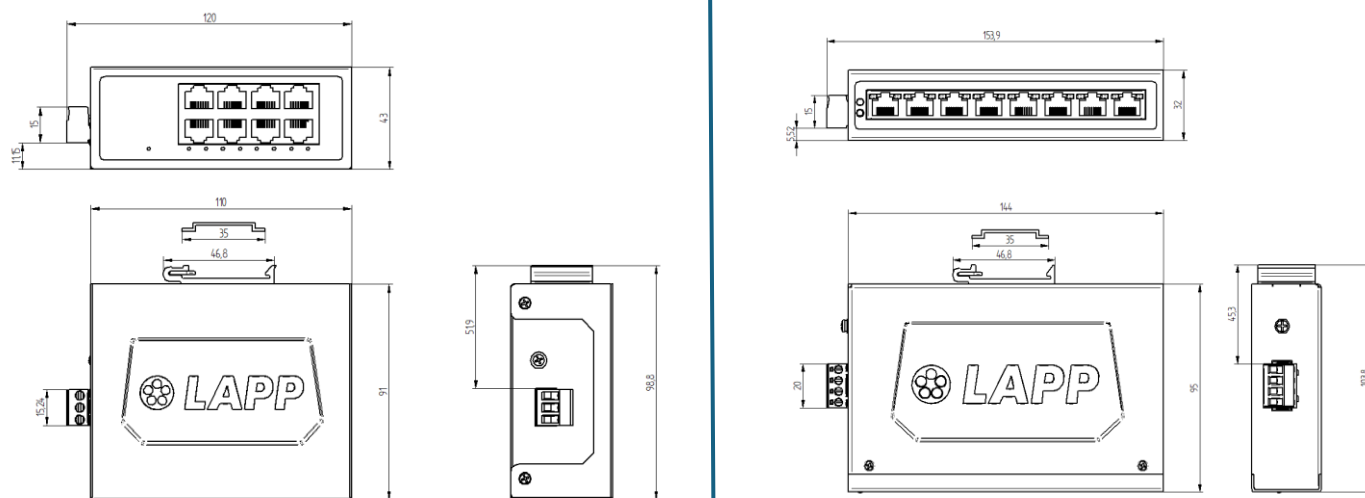

Figure 4 ETHERLINE ACCESS U08T-E-T and U08GT-E-T, Dimensions (unit: mm)



Caution:

As part of the heat dissipation system, the housing of the switch becomes hot while working.

Please do not touch or cover the housing while the switch is working.

3.2 Mounting

The device supports DIN-rail mounting.

Mounting Environment:

- 1) The temperature, humidity and power supply is within the allowable range.
- 2) No direct sunlight, distant from heat source and areas without strong electromagnetic interference.
- 3) The switches are open type equipment for indoor use.
- 4) The switches are intended for use in a Pollution Degree 2 industrial environment
- 5) The switches are recommended to be mounted in an enclosure that provides a minimum protection rating of IP54.



Note:

Devices should be installed and accessed by service personnel or users who have been instructed about the reasons for the restrictions applied to the location and about any precautions that shall be

3.2.1 DIN-Rail Mounting

Step 1: Select the mounting position for the device and guarantee adequate space and heat dissipation.

Step 2: Insert the connecting seat onto the top of the DIN rail, and push the bottom of the device inward and upward to ensure the DIN rail fits in the connecting seat. Make sure the device is firmly installed on the DIN rail, as shown in the following figure.

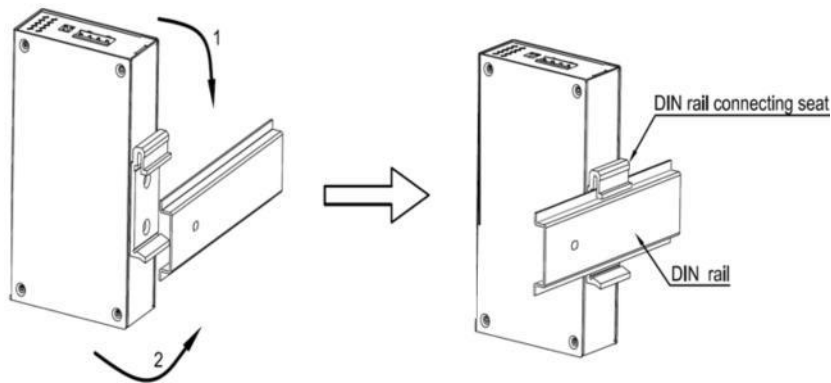

Figure 5 DIN-Rail Mounting

3.2.2 DIN-Rail Dismounting

Step 1: As shown in the following figure, press the device downward and move the device in direction 1 until the bottom of the device is detached from the DIN rail.

Step 2: Pull the device upward and move the device in direction 2 until the device is removed from the DIN rail completely.

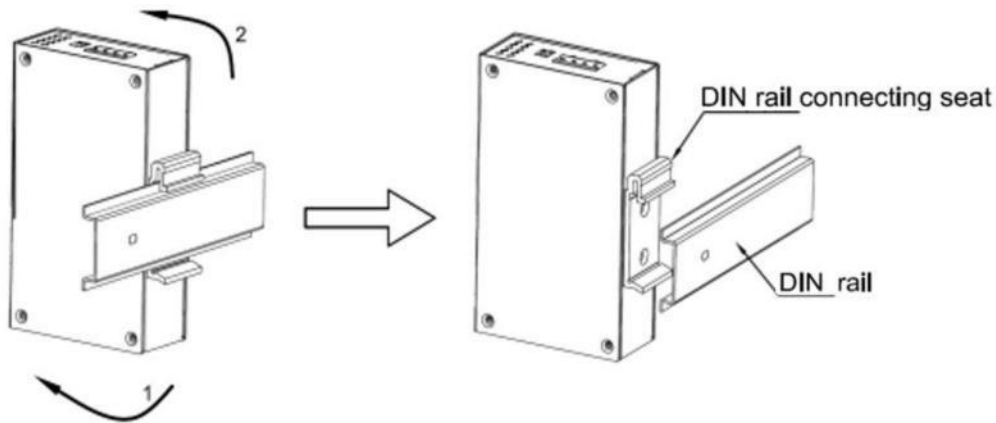

Figure 6 DIN Rail Dismounting



Caution:

Cut off the power and disconnect all cables before mounting, dismounting or moving the equipment.

4 Connection

4.1 10/100Base-T(X)/1000BaseT Ethernet Port

10/100Base-T(X) Ethernet port is equipped with RJ45 connector. The port is self-adaptive. It can automatically configure itself to work in 10M or 100M state, full or half duplex mode. The port can also adapt to MDI or MDI-X connection automatically. You can connect the port to a terminal or network device with a straight-through or cross-over cable.

- Pin Definition

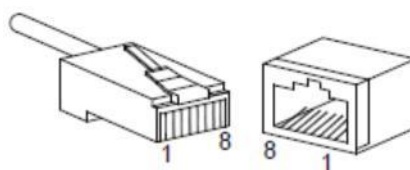

Figure 7 RJ45 Pin Definitions of 10/100Base-T(X) RJ45 Port

Port

Table 1

Pin	MDI-X Signal	MDI Signal
1	Receive Data+ (RD+)	Transmit Data+ (TD+)
2	Receive Data- (RD-)	Transmit Data- (TD-)
3	Transmit Data+ (TD+)	Receive Data+ (RD+)
6	Transmit Data- (TD-)	Receive Data- (RD-)
4, 5, 7, 8	Unused	Unused



Note:

+" and "-" indicate level polarities.

- Wiring Sequence

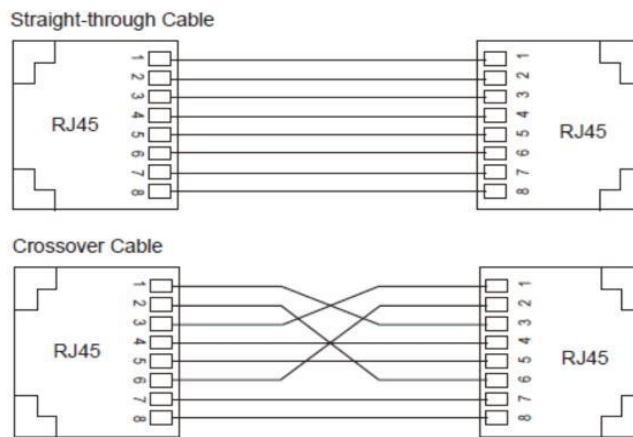

Figure 8 Connection Using Straight-through/Cross-over Cable



Note:

The color of the cable for RJ45 connector meets the 568B standard: 1-orange and white, 2-orange, 3-green and white, 4-blue, 5-blue and white, 6-green, 7-brown and white, and 8-brown.

4.2 Grounding

Grounding protects the device from lightning and interference. Therefore, you must ground the device properly. You need to ground the switch before it is powered on and disconnect the grounding cable after the device is powered off.

There is a grounding screw (see Figure 2) on the top panel for chassis grounding. After crimping one end of the grounding cable to a cold pressed terminal, secure the end of the grounding cable to the grounding screw and firmly connect the other end to ground.



Note:

Cross-sectional area of the chassis grounding cable > 2.5mm²; Grounding resistance < 5Ω.

4.3 Power Terminal Block

There is a power terminal block on the top panel of the device. You need to connect the power wires to the terminal block to provide power for the device. The switch supports redundant power supply with 4-pin 5.08mm-spacing plug-in terminal block. When one power input is faulty, the switch can continue operating properly, thereby improving network reliability.



Note:

- The maximum temperature rating of power wires to be connected to the power terminal block is 75 °C.
- All field wiring intended for connection to the power terminal shall consist of copper conductors with the insulation locally removed. Additional intermediate connecting parts, other than ferrules, shall not be used.
- 4-Pin 5.08mm-Spacing Plug-in Terminal Block

Table 2 Pin Definitions of 4-Pin 5.08mm-Spacing Plug-in Terminal Block

Pin Number	DC Wiring Definition
1	PWR1: -
2	PWR1: +
3	PWR2: -
4	PWR2: +

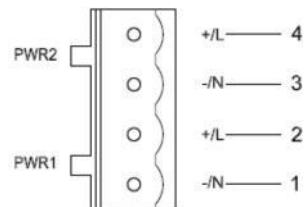

Figure 9 4-Pin 5.08mm-Spacing Plug-in Terminal Block (socket)

- **Wiring and Mounting**

Step 1: Ground the device properly according to section 4.2.

Step 2: Remove the power terminal block from the device.

Step 3: Insert the power wires into the power terminal block according to Table 2 and tighten the wires.

Step 4: Plug the terminal block with the connected wires into the terminal block socket on the device.

Step 5: Connect the other end of the power cable to an external power supply system within the allowed power range. If the corresponding power LED on the front panel of the switch turns on, the power supply is connected properly.

Table 3 Wiring and Mounting Specifications

Terminal Type	Required Torque	Wire Range (AWG)
Terminal Block Plug	0.5-0.56 Nm	12-24



Warning:

- Do not touch any exposed conducting wire, terminal, or component with a voltage warning sign, because it may cause personal injury.
 - Do not remove any part or plug in or out any connector when the device is powered on.
-

5 LEDs

Table 4 LEDs

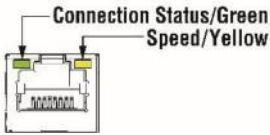
LED	State	Description
Power 1 LED	On	Power 1 is connected and operates properly.
	Off	Power 1 is not connected or operates abnormally.
Power 2 LED	On	Power 2 is connected and operates properly.
	Off	Power 2 is not connected or operates abnormally.
		
10/100Base-T(X) /1000 Base-T Ethernet port speed LED (yellow)	On	100M working state (100Base-TX)
	Off	10M working state or no connection
10/100Base-T(X)/1000 Base-T Ethernet port connection status LED (green)	On	Effective port connection /1000M working state
	Blinking	Ongoing network activities
	Off	No effective port connection

6 Basic Features and Specifications

Power Supply

Voltage Range	24V DC (18-36VDC)
Input Current	ETHERLINE ACCESS U05T-E-T: 0.72W@24VDC ETHERLINE ACCESS U08T-E-T: 1.1W@24VDC
Terminal Block	3-Pin 5 mm-Spacing Plug-in Terminal Block

Rated Power Consumption

Rated Power Consumption	ETHERLINE ACCESS U05GT-E-T: 1.1W@24DC ETHERLINE ACCESS U08GT-E-T: 4-Pin 5 mm-Spacing Plug-in Terminal Block
-------------------------	---

Physical Characteristics

Housing	Metal, fanless
Protection Class	IP40
Installation	DIN-Rail Mounting
Dimensions(W×H×D)	ETHERLINE ACCESS U05T-E-T: 26mm X 106mm X 84.8mm ETHERLINE ACCESS U05GT-E-T: 28mm X 106.9mm X 78.8mm ETHERLINE ACCESS U08T-E-T: 43mm x 120mm x 98.8mm ETHERLINE ACCESS U08GT-E-T: 32mm x 153.9mm x 103.8mm (Including the connectors, DIN rail)
Weight	ETHERLINE ACCESS U05TE-E/U05GT-E-T: ~0.21Kg ETHERLINE ACCESS U08T-E-T/U08GT-E-T: 0.35Kg

Environmental Limits

Ambient Temperature	-40°C to +75°C
Storage Temperature	-40°C to +75°C
Ambient Relative Humidity	5% ~ 95% (no condensing)
Altitude	2000m